



# COMMANDER BANKERS SAFE

MODEL CR10-B



for the security conscious



# COMMANDER

## BANKERS MODEL CR10-B

**ALL CMI SAFES COME WITH A FIVE YEAR WARRANTY, EXCLUDING FREIGHT AND TRAVELLING, WITH A 12 MONTH WARRANTY ON LOCKS.**

CMI Commander Bankers Safes are resisting to all known forms of attack.

The safe body and door provide a monolithic barrier for resisting thermic attack, explosives, drills and cutting tools.

The 38mm full through boltwork secures the safe at 14 points all activated by 32mm cam throw mechanism with multiple glass activated dead locking devices.

Two four wheel S&G combination locks with anti drive collars and dial check locks are standard. 2 x 20mm recessed bolt holes are provided in base.

CMI CR10-B comes with 6 x 250mm high dual key lockable cupboards as standard fittings.

Insurance surveyors have suggested \$500,000 as a realistic rating for overnight holding in CR10-B in an unsupported situation.

**FIRE RESISTANCE**  
The CR10-B safe has been designed to be fire resisting for one hour

	EXTERNAL DIMENSIONS	INTERNAL DIMENSIONS
<b>HEIGHT</b>	<b>1870mm</b>	<b>1675mm</b>
<b>WIDTH</b>	<b>792mm</b>	<b>585mm</b>
<b>DEPTH</b>	<b>855mm</b>	<b>550mm</b>

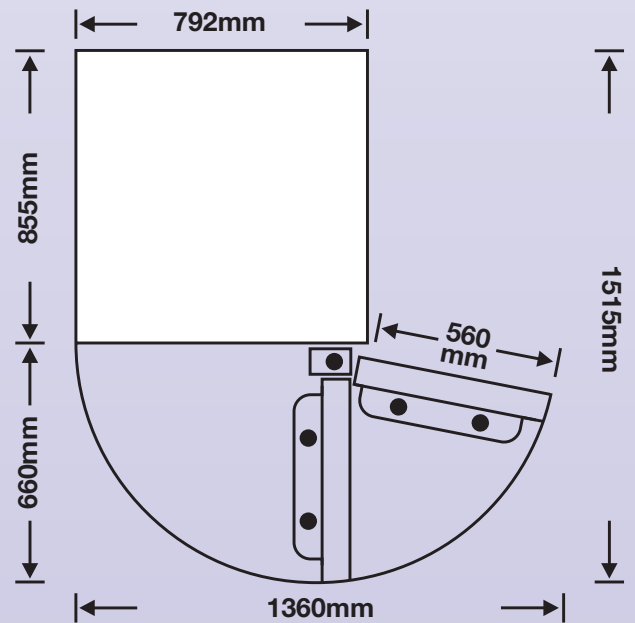

**PRICE INCL. GST \$**

**To deliver and install level access metro \$**

**BODY: 1610kg DOOR: 490kg**  
**CAPACITY: 539 LITRES**

**CMI SAFE CO.** ABN 20 118 637 245  
Head Office: 244 West Street, Carlton NSW 2218  
Phone: (02) 9547 1488 Fax: (02) 9547 2104  
Website: [www.cmisafe.com.au](http://www.cmisafe.com.au)  
Email: [sales@cmisafe.com.au](mailto:sales@cmisafe.com.au)



AVAILABLE FROM

**MADE IN AUSTRALIA**